



Visual Presenter



Owner's Manual

Model: QD700

PRECAUTIONS



WARNING!
Risk of electric shock
Dangerous voltage inside

Please follow these precautions:

To prevent fire or shock hazard, do not expose the unit to rain or moisture.

To prevent electrical shock, do not open the cabinet. Refer to qualified personnel for service only.

Do not use the unit continuously for more than 24 hours with camera auto focus on. It may cause damage to the camera lens.

Be careful not to spill water or other liquids onto the unit, or allow combustible or metallic objects to get inside the cabinet.

Unplug the visulizer from the wall outlet when it is not being used for a long period of time.

Clean the cabinet with a soft cloth lightly moistened with a mild detergent solution.

Clean the lens carefully with an air spray or soft dry cloth to avoid scratching it.

When the lamps flash or become dark, they should be replaced with new ones.

Avoid switching arm lights and back light frequently.

CONTACTS:

QOMO HITEVISION, LLC

Toll Free: 1-866-990QOMO

E-Mail: info@qomo.com

Web: www.qomo.com

CONTENTS:

PARTS IDENTIFICATION 4

CONTROL PANEL	4
BUTTON INSTRUCTION	5
REMOTE CONTROL	6
CONNECTIONS.....	7
BASIC PREPARATIONS	8
OUTPUT MODE AND VERTICAL FREQUENCY (60Hz)	12
PAL/NTSC VIDEO OUTPUTS.....	12
INSTALLING QOMO VISUALIZER SOFTWARE	12
WORKING ON THE STAGE	14
WORKING OUTSIDE THE STAGE.....	14
LIGHT.....	14
ADJUSTING IMAGE SIZE	15
WORKING WITH NEGATIVES	15
FOCUSING	15
FREEZING IMAGE	16
BRIGHTNESS ADJUSTMENT	16
WHITE BALANCE ADJUSTMENT	16
AUTO ADJUSTMENT	16
TEXT/IMAGE MODE.....	16
COLOR AND B&W MODE SWITCH	16
SWITCHABLE VIDEO INPUTS.....	17
SWITCHABLE RGB INPUTS	17
PROJECTOR ON/STANDBY	17
PROJECTOR INPUTS SELECTION.....	17
IMAGE REVERSION.....	18
IMAGE SPLIT.....	18
DYNAMIC/STATIC MODE SWITCH.....	18
TITLE FUNCTION.....	18
IMAGE SAVE AND RECALL	19
INFRARED REMOTE CONTROL	19
IMAGE SCROLLING	19
USB PORT.....	19
VIDEO DISPLAY AND CAPTURE.....	20
CONTROLLING THE VISUALIZER FROM A COMPUTER	21

CONTROLLING PROJECTOR WITH VISUALIZER 21
 FOLDING THE UNIT 25
 SPECIFICATIONS..... 26
 TECHNICAL SUPPORT 28

PARTS IDENTIFICATION

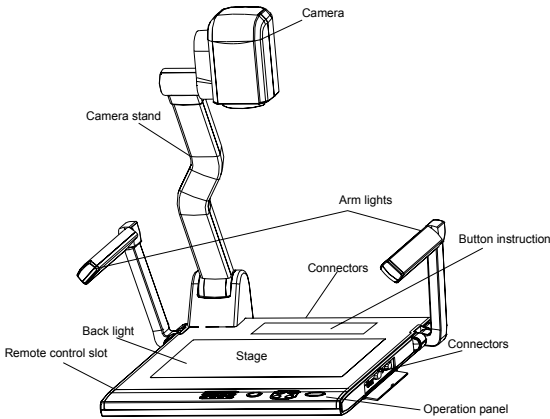

CONTROL PANEL

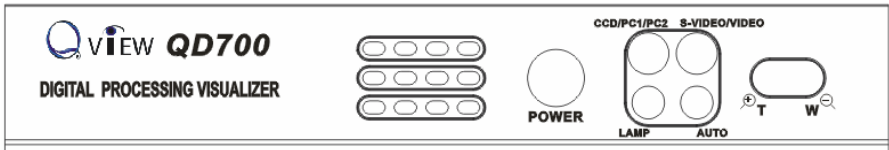

- POWER** (Control the visualizer On/Off)
- Mir** (V-reverse the image)
- Frz** (Freeze the image)
- Neg** (Display film negatives)
- Title** (Freeze the top 1/8 of the screen)
- D./S.** (Switch between static mode and dynamic mode)
- Far/Near** (Focus far or near)
- Split** (Image Split function)
- Ppw** (Control the projector On/Standby)
- Pin** (Projector input signal selection)

↑/↓ (Move the image up/down)

CCD/PC1/PC2 (CCD/RGB input signal selection)

S-VIDEO /VIDEO (Video input signal selection)

LAMP (Control the arm lights and back light)

AUTO (To auto adjust white balance and auto focus)

⊕/⊖ (Increase and decrease the magnification)

Remarks: Frz, Title, D./S. and Split functions are only available on PROJECTOR OUT port.

BUTTON INSTRUCTION

Button function instruction sheet

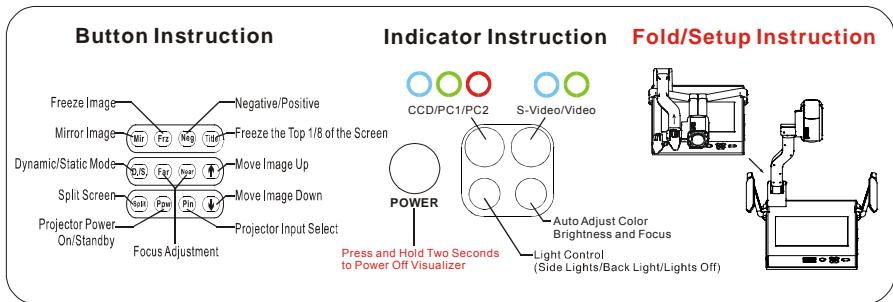

REMOTE CONTROL

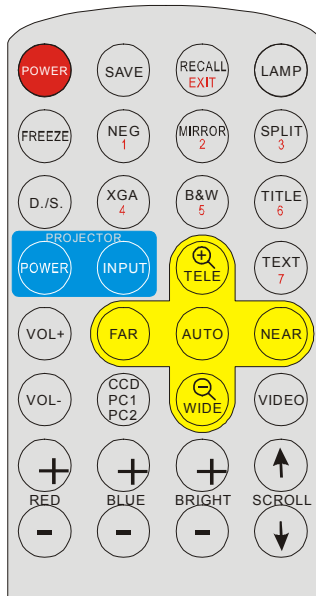

POWER (Control the visualizer On/Off)

SAVE (Save captured images)

RECALL (Display saved images)

EXIT (Exit RECALL mode)

LAMP (Control the arm lights and back light)

FREEZE (Freeze the image)

NEG (Display film negatives)

MIRROR (V-Reverse the image)

SPLIT (Image split function)

D./S. (Switch between static mode and dynamic mode)

XGA (Switch between XGA (1024 x 768) and SVGA (800 x 600) mode)

B&W (Switch between color mode and B&W mode)

TITLE (Freeze the top 1/8 of the screen)

PROJECTOR POWER (Control the projector On/Standby)

PROJECTOR INPUT (Projector input signal selection)

TEXT (Switch between image/text mode)

AUTO (To auto white balance and auto focus)

⊕TELE/WIDE⊖ (Increase and decrease the magnification)

FAR/NEAR (Focus near or far)

VOL+/VOL- (Increase or decrease the volume)

CCD/PC1/PC2 (CCD/RGB input signal selection)

VIDEO (Video input signal selection)

RED +/- (Increase/decrease the red hue)

BLUE +/- (Increase/decrease the blue hue)

BRIGHT +/- (Increase/decrease the brightness)

SCROLL ↑/↓ (Move the image up/down)

Remarks: FREEZE, TITLE, D./S. and SPLIT functions are only available on PROJECTOR OUT port.

CONNECTIONS

Rear Panel



Side Panel

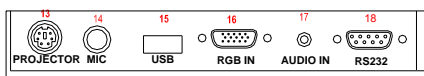

#1 AUDIO OUT

#2 VIDEO OUT

#3 S-VIDEO OUT

#4 VIDEO AUDIO IN

#5 VIDEO IN

#6 S-VIDEO AUDIO IN

#7 S-VIDEO IN

#8 PC AUDIO IN

#9 PROJECTOR Connector

#10 COMPUTER OUT

#11 COMPUTER IN

#12 POWER OUT/IN

#13 PROJECTOR RS232 Connector

#14 MIC IN

#15 USB Connector

#16 RGB IN

#17 RGB AUDIO IN

#18 COMPUTER RS-232 Connector

BASIC PREPARATIONS

1. Use one hand holds the base of the visualizer, use the other hand carefully lift up the camera stand of the unit.

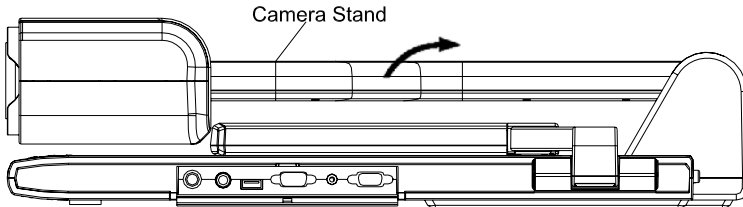

2. Open the arm lights and rotate the camera head until they are in proper positions.

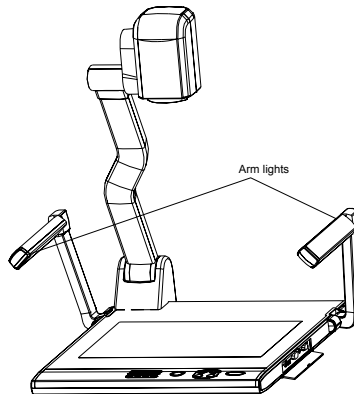

3. Making connections:

Before making any connection, **turn off all the power**, including power of the visualizer and the equipment to be connected.

Step 1: Connect power source.

First connect the power cord to the **12V IN** connector.

Step 2: Connect to the projector.

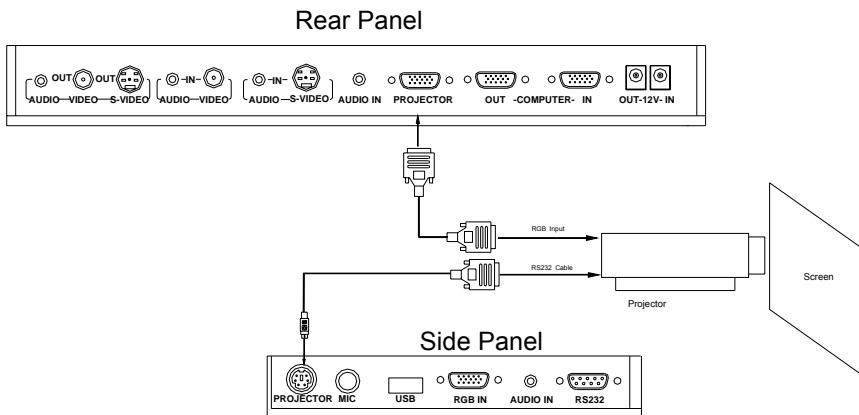

Connect visualizer's PROJECTOR port to the RGB IN port of the projector port with the RGB cable provided together the visualizer. If you need control a projector with the visualizer, please use the projector RS232 cable (6-pin to 9-pin) to make the connection between the projector and the visualizer. Some projector models may require a converter cable in addition to this standard RS232 cable to connect to the projector control port, for the pin locations and shape of some projectors' control port connector may be different from the connector of a standard RS232 cable. After the visualizer is connected to the projector, you can control projector's power on, standby and input selection with the visualizer. (For projectors other than Hitachi, the Code Writing program that comes with the visualizer is required for this function.)

Step 3: Connect to a desktop computer.

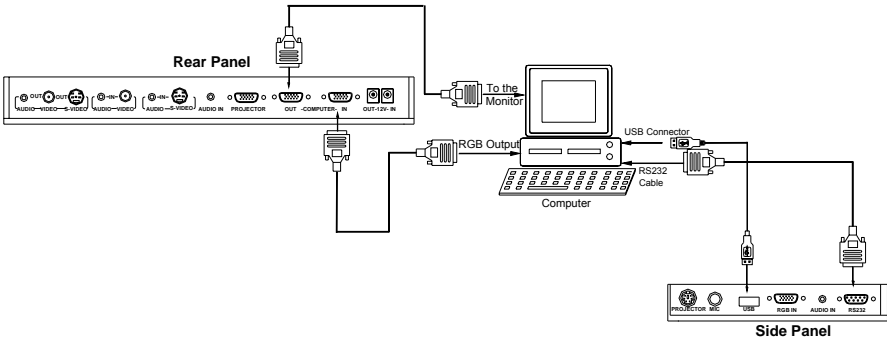

Note: You can connect a laptop computer to the RGB IN port of side panel with a RGB cable.

Step 4: Connect to the first video equipment with S-Video input.

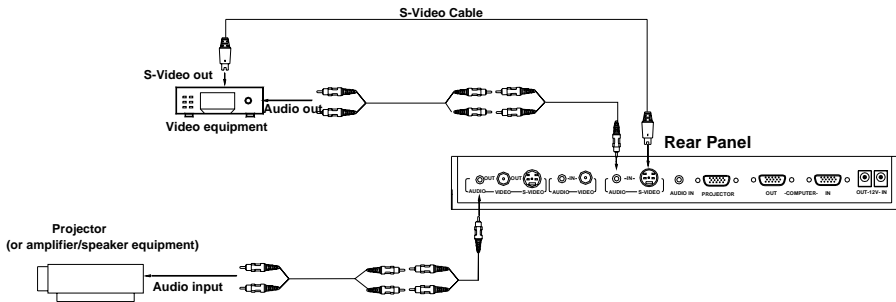

Output of the S-Video signal from the visualizer to the projector is already done in the step 2, where the RGB cable comes out from the visualizer and goes to the projector. After the connections as steps 2, 3, 4 are made, input signals from the computer, visualizer CCD and S-Video are going to the RGB1 input on the projector and will be displayed on the projector screen as RGB1. These signals can be seen in turn when pressing “CCD/PC1/PC2” and “S-VIDEO/VIDEO” on the control panel of the visualizer.

Remarks: RGB IN signal can not go to S-VIDEO OUT or VIDEO OUT port to be displayed on the screen.

Step 5: Connect to the second video equipment with video input.

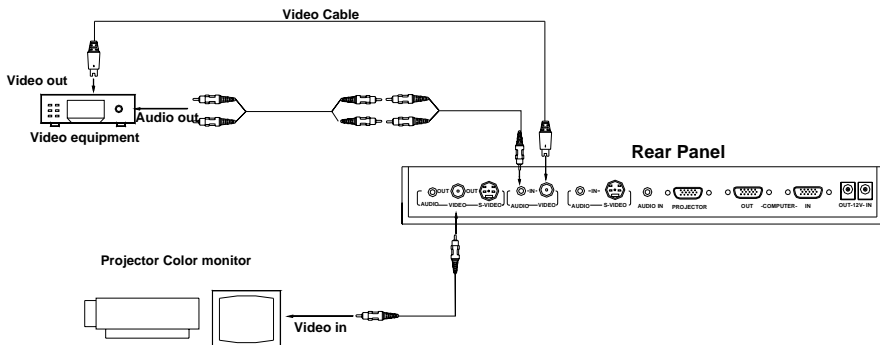

Step 6: Connections for external control from the computer.

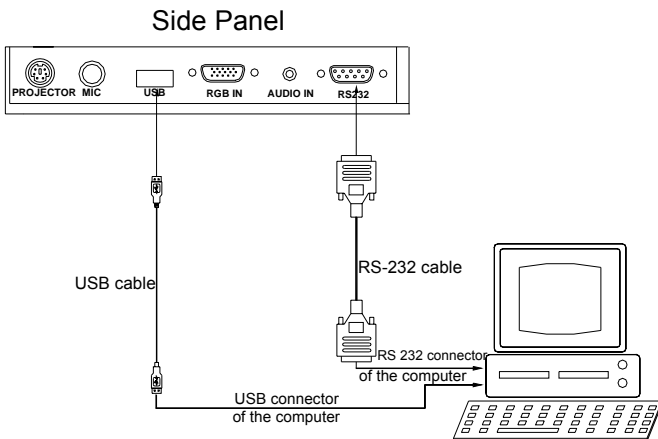

Use the computer RS232 cable (9-pin to 9-pin) to make the connections shown below to control the visualizer from an external computer.

USB connection enables capturing still images / video streams from the visualizer to the computer. Special software is required for this operation.

4. Turn on the power by pressing the “POWER” button.

OUTPUT MODE AND VERTICAL FREQUENCY (60Hz)

The RGB output can output a signal in the SVGA /XGA format.

In order to achieve the best picture quality you must set the outputs of the visualizer to match the native resolution of your display unit.

PAL/NTSC VIDEO OUTPUTS

The S-Video and composite video outputs are set to PAL (NTSC) during manufacturing.

INSTALLING QOMO VISUALIZER SOFTWARE

This function is to snap and display images with the USB interface, which includes displaying static and dynamic pictures, snapping dynamic images and playback the dynamic images with the Windows Media Player or its own player.

- A. Insert the CD-ROM that comes with your visualizer into the CD-ROM drive. If Autorun is enabled on your system, then the QOMO Software Setup window will be displayed automatically as below.



- B. Click the **Install Code-Writing Program** button to install Code-Writing Program.
- C. Click the **Install DirectX9.0** button to install Microsoft DirectX

9.0.

- D. Click the **Install Capture Program** button to install the program that captures images in the AVI or JPG format.
- E. Click the **Install USB Driver** button to install the driver designed for the visualizer and will be used by the Capture Program.
- F. After the installation is finished, then click the **Exit** button to exit the Software Setup window.
- G. Shut down your computer when prompted so the changes will take effect.
- H. Use the USB cable to connect your computer to the visualizer before your computer is restarted.
- I. Turn on the visualizer.

Remarks: DirectX9.0 is not necessary to install, it is mainly for computer print screen function.

Please pay attention to the following:

- 1. Computer hardware requirement: CPU: Pentium 4, RAM: 256M or above, USB 2.0 port, Hard disk 40G or more
- 2. Operating system: Windows 2000 or above. If the operating system is Windows 2000, should install SP4. If the operating system is Windows XP, should install SP1.
- 3. Must use the high-speed USB cable provided together with the visualizer.
- 4. When connect the visualizer to a desktop computer with the high-speed USB cable provided together with visualizer, we recommend using the USB port on the rear of the mainframe as the USB port on the front of the computer might have interference.
- 5. You need to install the USB driver again when you change a computer's USB port. If this port has installed USB2.0 driver, then no need to install USB driver again.
- 6. When you open capture program, but can not capture the image, please set the signal input source: click "Option"→"Video Crossbar", and then set INPUT as Video Composite In.

WORKING ON THE STAGE

1. Place your material on the working surface.
2. Select the enlargement required with the “ \oplus T” and “W \ominus ” keys.
3. Adjust the focus with the “Near” and “Far” keys or “AUTO” key.

WORKING OUTSIDE THE STAGE

For showing 3-dimensional objects with the visualizer, just place them on the working surface and adjust the “ \oplus T” or “W \ominus ” and “AUTO” keys. If the object is too big for the stage or you want to show it from the side, just place it behind or in front of the unit and tilt the camera by hand (please take off the close-up lens first).

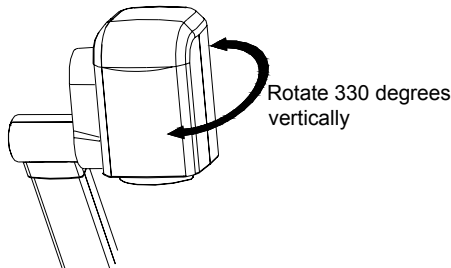

LIGHT

The arm lights are on when the power is on. Each time you press the “LAMP” buttons, the lighting changes as below.

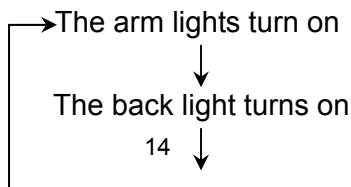

All the lights turn off

ADJUSTING IMAGE SIZE

In order to reduce or enlarge the image size displayed on the screen, press the “⊕T” or “W⊖” button.



WIDE



TELE

WORKING WITH NEGATIVES

The visualizer is automatically set to display normal materials on the screen when the power is on. To display negatives, turn on the backlight by pressing the “LAMP” key, and then press the “Neg” button to display the film negatives. Press the “Neg” button again to display normal materials in the color mode.



Positive

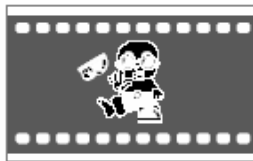

Negative

FOCUSING

When the Visualizer is turned on the focus automatically adjusts to the stage, it is not necessary to readjust the focus if you are only working with flat materials (text, photos, etc.). Only 3D objects require a focus adjustment.

Press the “AUTO” button to auto focus.

Press the “FAR” or “NEAR” button once to focus manually.

FREEZING IMAGE

Press the “Frz” button to freeze the image. When the output signal is RGB, in order to show a still image on the screen, press the “Frz” button. The frozen image can’t be adjusted (Zoom in/out, color adjustment, etc.).

Note: This function is not available on S-Video and Video output.

BRIGHTNESS ADJUSTMENT

If the image effect is not satisfactory, you can adjust the brightness to get a better image effect. Use the “BRIGHT +” or “BRIGHT -” button to adjust the brightness. To increase the brightness, press the “BRIGHT +” button. To decrease it, press the “BRIGHT -” button. To go back to the initial brightness press the “AUTO” button.

WHITE BALANCE ADJUSTMENT

Each time the lighting condition changes, the user should adjust the white balance of the CCD.

Press the “AUTO” button to adjust the white balance automatically.

AUTO ADJUSTMENT

One of the QD700’s special functions is auto adjustment. Press the “AUTO” button to auto adjust the white balance and the focus. The whole process takes about 10 seconds.

TEXT/IMAGE MODE

Press the “TEXT” button to switch between image/text modes. To display a text file, switch to the text mode to get a clearer text effect. (On the remote control)

COLOR AND B&W MODE SWITCH

Press “B&W” once to enter the Black & White mode; Press again to return to the Color mode.

SWITCHABLE VIDEO INPUTS

Press the “S-VIDEO/VIDEO” button to switch among S-Video and Video signals.

SWITCHABLE RGB INPUTS

Use the “CCD/PC1/PC2” button to switch among CCD and different RGB signals. Each time the “CCD/PC1/PC2” button is pressed, it provides seamless transitions among different sources such as Camera (CCD)、COMPUTER(IN)、and RGB (IN).

Notes: RGB OUT always outputs RGB IN signals.

PROJECTOR ON/STANDBY

Press the “POWER” button to turn on the visualizer’s power and press the “Ppw” button to turn the projector power on. To turn the projector standby after use, press the “Ppw” button more than 2 seconds, and then the projector enters to the stand-by mode. (On the remote control, press the “PROJECTOR POWER” button)

Note: Please connect the projector RS232 cable between the projector and the visualizer first. If you cannot switch projector inputs by pressing this button, you need to manually program the RS232 code into the visualizer. See the section “Controlling Projector with Visualizer” for detailed instruction.

PROJECTOR INPUTS SELECTION

When the projector is connected to several input sources, use the “Pin” button to switch signal inputs of the projector. (On the remote control, press the “PROJECTOR INPUT” button)

Note: Please connect the projector RS232 cable between the projector and the visualizer first. If you cannot switch projector inputs by pressing this button, you need to manually program the RS232 code into the visualizer. See the section “Controlling Projector with Visualizer” for detailed instruction.

IMAGE REVERSION

Press the “Mir” button once to V-reverse the image and the vertically mirrored image will be displayed. Press the “Mir” button again to exit. (On the remote control, please press the “MIRROR” button)

IMAGE SPLIT

Press “SPLIT”, the image will be split into two images. One is the current captured image the other is a frozen image of the last image, Press the “SPLIT” button again to exit.

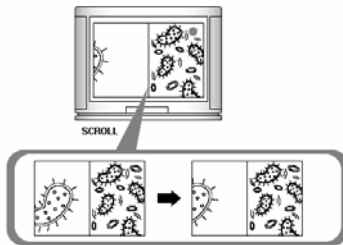

Note: This function is not available on S-Video and Video output.

DYNAMIC/STATIC MODE SWITCH

To display dynamic images, Press the “D./S.” button to switch to the Dynamic mode, the image will be clear and has no choppy strobe effect. To display still images, press the “D. / S.” button switch to the Static mode.

Note: This function is not available on S-Video and Video output.

TITLE FUNCTION

Press the “Title” button once, the image split into two parts, the upper 1/8 part of the image will freeze and stay on top 1/8 of the screen. Press “Title” button again to exit the Title mode.

Note: This function is not available on S-Video and Video output.

IMAGE SAVE AND RECALL

Press the “SAVE” button once to save one captured images, it can save up to 7 images. After 7 images are saved, the 8th image will replace the previous 1st image and will become the new 1st saved image. (On the remote control)

Press the “RECALL” button once to display the saved images, then press the numerical button to show the corresponding image. For example: Press “2” to display the second image. At this status, the function under each numeric key is not available. Press “RECALL” again to exit this mode. (On the remote control)

INFRARED REMOTE CONTROL

The QD700’s remote control can control the camera from different angels. Please note that an infrared remote control can only be used up to a certain distance to the unit. Objects situated between the visualizer and the infrared remote control and a weak battery may interfere with the reception.

On the left side of the visualizer stage, there is a built-in remote control storage compartment where you can store the remote control when you not use it.

IMAGE SCROLLING

Press the “↑” button to scroll the image down to display the upper part of the image. Press the “↓” button to scroll the image up to display the lower part of the image.

USB PORT

The USB port can be used to transfer still images from the visualizer to a computer. No additional computer hardware is required. In this way, the visualizer can be used as a 3-D scanner for your computer. Connect the visualizer to your computer with the supplied USB cable. The visualizer software is available on the supplied CD-ROM.

VIDEO DISPLAY AND CAPTURE

A. Static Images Snap

Select [Start] -> [All Programs] -> [QOMOCap] -> “QOMOCap” to open the QOMOCap.exe. Click [File] -> [Set Capture File] to locate the image file into your desired folder. Then click [Set Frame File Name] to input the name of the file. Click [Capture] -> [Capture Frame] to save the static image.

B. Snap Video Stream

Click [File] -> [Set Capture File] to select the location of the file to be saved. Then input the name of the file. Click [Capture] -> [Start Capture] to start capture, and click [Capture] -> [Stop Capture] to stop. If you want to set the time limit for the capture, select [Capture] -> [set time limit] to set the time limit. (If you have set the time limit, it will stop automatically when the time is up.)

C. Display and Edit the Static Image

You can use the “Imaging” or “Paint” tool to display and edit the static image. To run a tool, click [Start] -> [All Program] -> [Accessories] -> “Imaging” or “Paint” to open a picture.

D. Play Video Stream

Click [Start] -> [All Programs] -> [Accessories] -> [Entertainment] -> “Windows Media Player” or “ActiveMovie control”. You can also click [File] -> [Display Captured Video Stream] to play video stream in the QOMOCap program.

E. Set the Frame Rate

Click [Capture] -> [Set Frame Rate], and click open “Choose Frame Rate” to set the frame rate.

F. Set Time Limit

Click [Capture] -> [Set Time Limit] to set the time limit while capturing video.

G. Control the CCD

Click [Option] -> [Video Capture Filter] -> [Video Proc Amp], open the dialog to adjust “Brightness”, “Contrast”, etc. Use “Default” to set each parameter to the default.

H. Note:

Don't connect / disconnect the USB cable when the application is running, it will cause the program to be interrupted.

CONTROLLING THE VISUALIZER FROM A COMPUTER

You can control the visualizer from a computer connected with a RS232 connector.

- A. Connect the computer and the visualizer with the computer RS-232 cable (9-pin to 9-pin).
- B. Select [Start] -> [Program] -> [QOMOCap] -> “QOMOCap” to open the QOMOCap.exe.
- C. Click “Visualizer Control” under “Capture”.
- D. Select the COM port COM1 or COM2, and you can control the visualizer by clicking the buttons on the menu.

CONTROLLING PROJECTOR WITH VISUALIZER

The code writing software is used to inputting projector's control code, then can control various projector with the visualizer.

1. Connect the visualizer to the projector with the RGB、VIDEO、S-VIDEO cables.
2. Connect the RS232 cable to the computer's connector. The visualizer's RS232 port is located on its right side.
3. After completion of the connection, turn on the visualizer, click [start] -> [All Programs] -> Visualizer ->  Visualizer Code-Writing and the following dialog box appears as below:

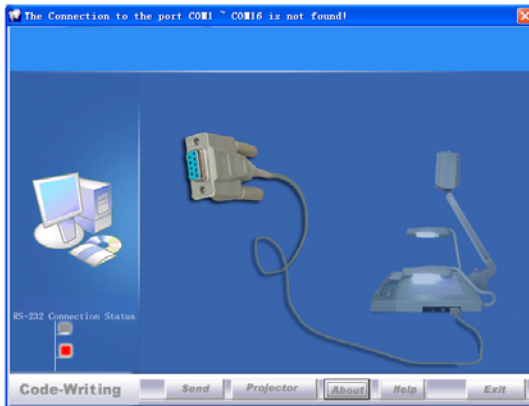

When the indicator of “Current RS-232 Connection Status” is green, that means the connection between the visualizer and the computer’s RS232 connector is good. If the indicator is red, please check if the RS232 cable is connected correctly. When all the cables are connected correctly, please click “Projector” to select your projector model under the drop-down list, then click “Send”. If you can not find your particular projector model in the “Projector”, please do the following:

- 1). Select “Baud rate” and “parity” and input the projector control code. (The baud rate, parity and control code is supplied by projector’s manufacturer, please refer to the projector’ manual)

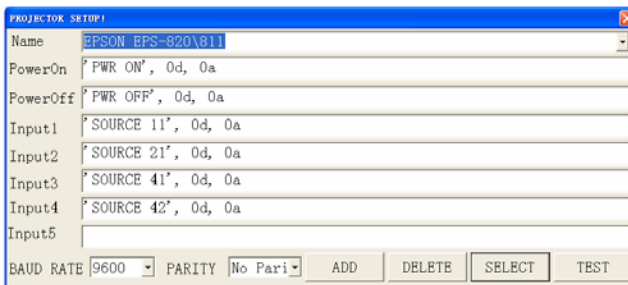

The input format of projector’s control code is as follows:

- a. If the data is in the numerical value format, please input data directly, block them off with comma, do not distinguish lowercase and uppercase.

For example: the “POWER ON” code in Hitachi projector manual is :

BE EF	03 06 00	BA D2	01 00	00 60	01 00
-------	----------	-------	-------	-------	-------

In the POWRE ON box, Input : be, ef, 03, 06, 00, ba, d2, 01, 00, 00, 60, 01, 00. Then use the same input rule to input other code.

b. If the data is in the character string format, input ‘character string’.

For example: the “POWER ON” code in the SHARP C40/50 projector manual is :

P	O	W	E	-	-	-	1	
---	---	---	---	---	---	---	---	---

(“-“ is space,  is enter.)

In the POWER ON box, input ‘POWER 1’, 0d, 0a

(Remarks: There are 3 spaces after POWER, 0d, 0a is enter.)

Input other codes in the same way.

c. If the data is in the numerical value and character format, then synthesize the above-mentioned formats.

3). Once done, click “Add” to add your projector model, then Click “Send”. Afterward, click “Ok”. Now, you can use the visualizer to control your projector.

4. Connect the visualizer’s projector control port to the RS232 port with a RS232 cable(Please disconnect the computer from the RS232 port first) . Then use buttons on the operation panel to control the projector.

The visualizer provides a 6-pin to 9-pin RS232 cable. If this cable does not match to your projector’s RS232 port, an additional RS232 cable is needed. This additional RS232 cable can be made based on the pin location of the projector’s RS232 control port. The pin locations of the visualizer are: the pin 1 is RXD (Received Data); the pin 5 is TXD (Transmitted Data); the pin 4 is GND (Ground). Other pins are not defined. The pin location information of the projector is provided by the projector’s manufacturer. The projector’s RS232 control port normally has RXD pin, TXD pin and GND pin, the name may be different. The parallelism of each data pin is shown as

follows:

- Visualizer's RXD pin-----Projector's TXD pin
- Visualizer's TXD pin-----Projector's RXD pin
- Visualizer's GND pin-----Projector's GND pin

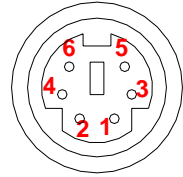

5. If you can not use buttons on the operation panel to control the projector, please use Code-Writing software's projector control code testing function to check if the control code is correct.

Click "Projector" button, the following dialog box appears as below:

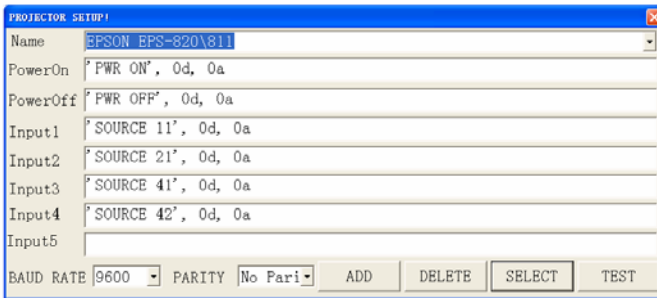

Connect the visualizer to a computer with a RS232 cable (Please disconnect the projector from the RS232 port first) and select the Baud Rate and Parity based on the projector's Baud Rate, then click the "TEST" button to pop up the Projector Code Test dialog box, input the Baud Rate and Parity based on the projector's Baud rate, then click "Open".

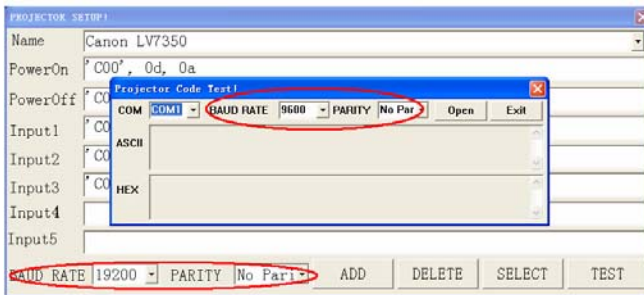

Click the projector control buttons on the visualizer's operating panel to check if the control code that the program received is the same as

the sending code. If the receiving code is same to the sending code, the input codes are correct. If the visualizer can not control the projector, please do the following.

1. Check to see if the source control codes of projector are correct.
2. Check to make sure the connection between the visualizer and the projector is correct.

FOLDING THE UNIT

1. **Fold** the right arm light down first onto the base, then the left arm down. **Rotate** the camera head clockwise until the camera head is parallel to the camera stand.

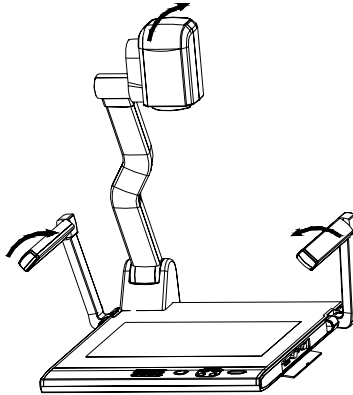

2. Carefully **Fold** the camera stand down to the front panel.

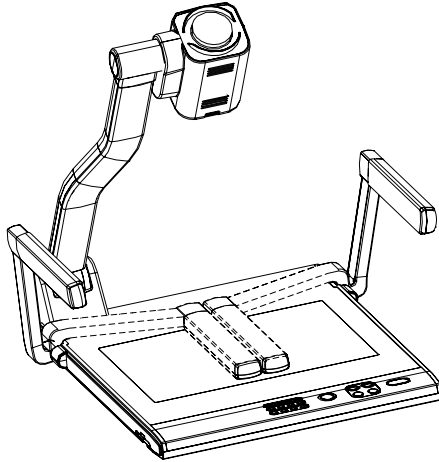

Cautions:

- a. Don't lay the unit down flat.
- b. Don't try to stand it on its rear or sides.
- c. Don't try to pick up this unit by pulling the camera stand.

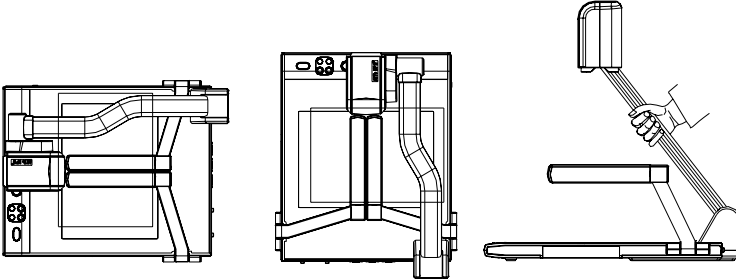

NOT THIS WAY

SPECIFICATIONS

Color system	NTSC or PAL system
Pickup device	1/4 " professional CCD
Resolution	XGA (1024 x 768), SVGA(800 x 600)
Total Pixels	470,000

RGB Output Pixels	780,000
Lens	22 x optical zoom, 10 x digital zoom
	F=1.6~3.7mm / f=3.9~85.8 mm
Focus/Iris	Auto/manual selectable
White balance	Auto
Image split	Yes
Negative/positive conversion	Yes
Black/white and color selection	Yes
Image Freeze	Yes
Mirror	Yes
Lights	Arm light: 1.5 W LED lamps x 2
	Back light: 4 W LED lamps
Input connectors	C-Video: RCA jack 1
	S-Video: 4 pin mini Din 1
	Audio: Mini jack 2
	MIC: Mini jack 1
	PC Audio: Mini jack 2
Output connectors	RGB: DB15FLC 2
	RGB DB15FLC 2
	C-Video: RCA jack 1
	S-Video: 4 pin mini Din 1
Audio: Mini jack 1	
Operating system	Windows 2000/XP
USB connector	30 frames/sec
RS-232 connector	9-pin, D-Sub, male/6-pin PS/2
USB port	USB 2.0
Power requirements	12V/4A external AC adapter
Dimension (W x D x H)	Folded: 20.0" x 16.1" x 4.7"
	Setup: 20.0" x 20.9" x 22.4"
	Packing: 25.6" x 21.3" x 9.1"
Weight	N.W: 5.5Kg (12.1lbs)

	G.W: 9.5Kg (20.9 lbs)
Accessory	AC power cord RGB cable Audio/Video cable S-Video cable Computer RS232 cable (9-pin to 9-pin) Projector RS232 cable (6-pin to 9-pin) USB cable Audio convert cable AC adapter User's manual Quick Start-up guide Software CD Infrared remote control Warranty card

* Design and specifications are subject to change without notice.

TECHNICAL SUPPORT

How to Reach QOMO:

By Phone

Call us at 1-866-990QOMO. Our expert personnel provide technical assistance from 9:00AM through 5:00PM Eastern Standard Time, Monday through Friday. Please gather the following information before calling:

- Product model name(s) and numbers
- Product serial number(s)
- Detailed and specific questions

Online

Technical support is also available online at QOMO's web site at www.qomo.com. You can enter your questions and concerns through our online form. Or you can email us at info@qomo.com.

Copyrights © 2004 QOMO Hitevision, LLC. All Rights Reserved.

QOMO HITEVISION, LLC

Toll Free: 1-866-990QOMO

E-Mail: info@qomo.com

Web: www.qomo.com