



Visual Presenter



Quick Start-up Guide

Model: QD700



Turn off all power while setting up and making connections.

SETTING UP THE UNIT

1. Use one hand holds the base of the visualizer, use the other hand carefully lift up the camera stand of the unit.

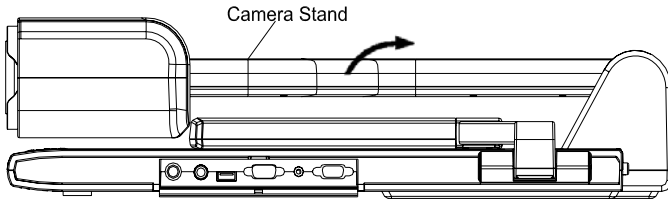

2. Open the arm lights and rotate the camera head until they are in proper positions.

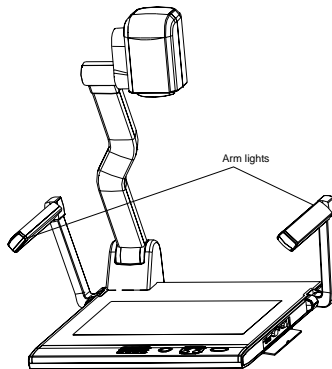

MAKING CONNECTIONS

Before making any connection, **turn off all the power**, including power of the visualizer and the equipment to be connected.

Step 1: Connect power source.

First connect the power cord to the 12V IN connector.

Step 2: Connect to the projector.

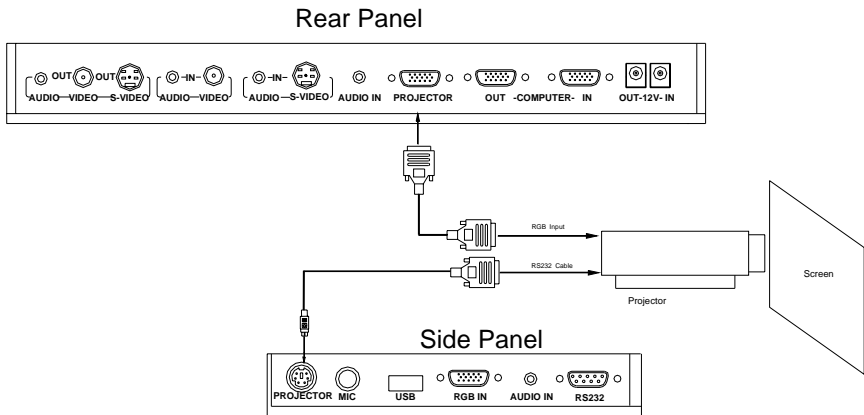

Connect visualizer's PROJECTOR port to the RGB IN port of the projector port with the RGB cable provided together the visualizer. If you need control a projector with the visualizer, please use the projector RS232 cable (6-pin to 9-pin) to make the connection between the projector and the visualizer. Some projector models may require a converter cable in addition to this standard RS232 cable to connect to the projector control port, for the pin locations and shape of some projectors' control port connector may be different from the connector of a standard RS232 cable. After the visualizer is connected to the projector, you can control projector's power on, standby and input selection with the visualizer. (For projectors other than Hitachi, the Code Writing program that comes with the visualizer is required for this function.)

Step 3: Connect to a desktop computer.

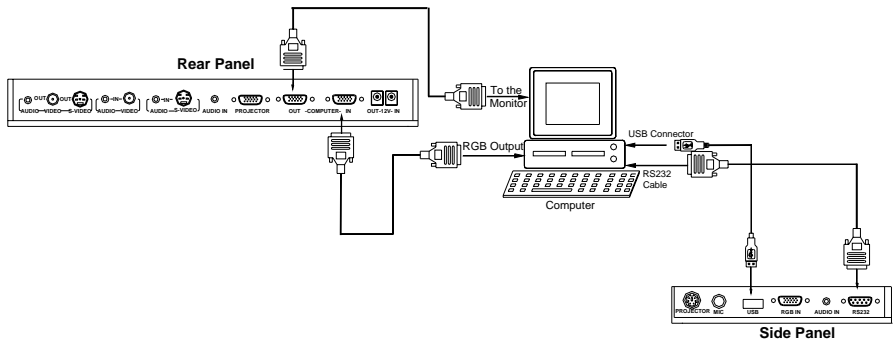

Note: You can connect a laptop computer to the RGB IN port of side panel with a RGB cable.

Step 4: Connect to the first video equipment with S-Video input.

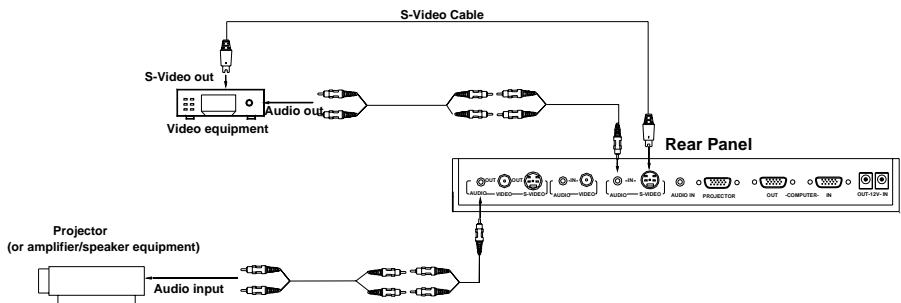

Output of the S-Video signal from the visualizer to the projector is already done in the step 2, where the RGB cable comes out from the visualizer and goes to the projector. After the connections as steps 2, 3, 4 are made, input signals from the computer, visualizer CCD and S-Video are going to the RGB1 input on the projector and will be displayed on the projector screen as RGB1. These signals can be seen in turn when pressing "CCD/PC1/PC2" and "S-VIDEO/VIDEO" on the control panel of the visualizer.

Remarks: RGB IN signal can not go to S-VIDEO OUT or VIDEO OUT port to be displayed on the screen.

Step 5: Connect to the second video equipment with video input.

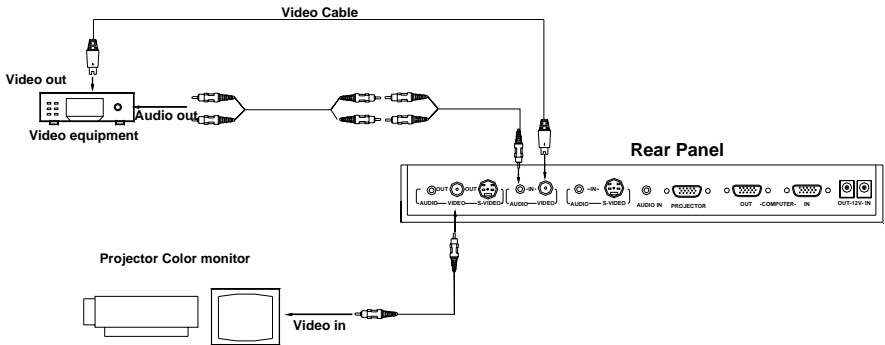

Step 6: Connections for external control from the computer.

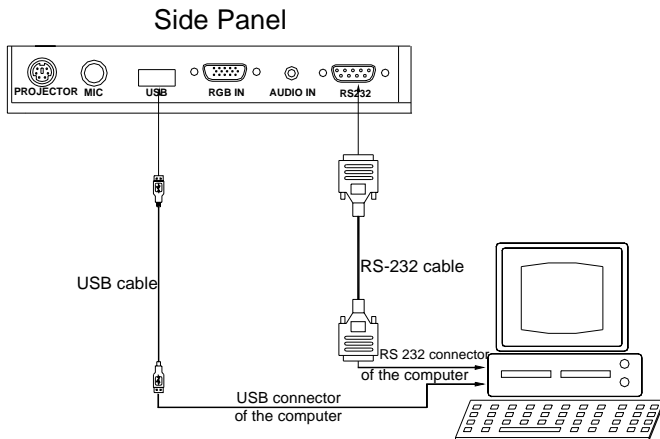

Use the computer RS232 cable (9-pin to 9-pin) to make the connections shown below to control the visualizer from an external computer.

USB connection enables capturing still images / video streams from the visualizer to the computer. Special software is required for this operation.

4. Turn on the power by pressing the “POWER” button.

QOMO HITEVISION, LLC

Toll Free: 1-866-990QOMO

E-Mail: info@qomo.com

Web: www.qomo.com