

PRECAUTIONS



Please follow these precautions:

To prevent fire or shock hazard, do not expose the unit to rain or moisture.
To prevent electrical shock, do not open the cabinet. Refer to qualified personnel for service only.

Do not use the unit continuously for more than 24 hours with camera auto focus on. It may cause damage to the camera lens.

Be careful not to spill water or other liquids onto the unit, or allow combustible or metallic objects to get inside the cabinet.

Unplug the visualizer from the wall outlet when it is not being used for a long period of time.

Clean the cabinet with a soft cloth lightly moistened with a mild detergent solution.

Clean the lens carefully with an air spray or soft dry cloth to avoid scratching it.

When the lamps flash or become dark, they should be replaced with new ones.

Avoid switching arm lights and back light frequently.

CONTACTS:

QOMO Hitevision, LLC

Toll Free: 1-866-990QOMO

E-Mail: info@qomo.com

Web: www.qomo.com

CONTENTS:

PARTS IDENTIFICATION	3
CONTROL PANEL	3
BUTTON INSTRUCTION.....	4
REMOTE CONTROL	5
CONNECTIONS	6
BASIC PREPARATIONS.....	7
OUTPUT MODE AND VERTICAL FREQUENCY (60Hz).....	11
PAL/NTSC VIDEO OUTPUTS	11
INSTALLING VISUALIZER SOFTWARE	11
WORKING ON THE STAGE	14
WORKING OUTSIDE THE STAGE.....	14
LIGHT	14
ADJUSTING IMAGE SIZE	15
WORKING WITH NEGATIVES	15
FOCUSING	15
FREEZING IMAGE	16
BRIGHTNESS ADJUSTMENT	16
WHITE BALANCE ADJUSTMENT	16
AUTO ADJUSTMENT	16
TEXT/IMAGE MODE.....	16
COLOR AND B&W MODE SWITCH.....	16
SWITCHABLE VIDEO INPUTS	16
SWITCHABLE RGB INPUTS.....	17
PROJECTOR ON/STANDBY	17
PROJECTOR INPUTS SELECTION.....	17
IMAGE ROTATION	17
IMAGE REVERSION	17
INFRARED REMOTE CONTROL.....	17
PRESET FUNCTION	18
2 X 2 MULTIPLE SCREEN DISPLAY.....	18
USB PORT.....	18
USB IMAGE CAPTURE	19

CONTROLLING THE VISUALIZER FROM THE COMPUTER	20
CONTROLLING PROJECTOR BY VISUALIZER.....	20
CONTROLLING CAMERA BY MOUSE	24
FOLDING THE UNIT.....	24
SPECIFICATIONS	26
TECHNICAL SUPPORT.....	28

PARTS IDENTIFICATION

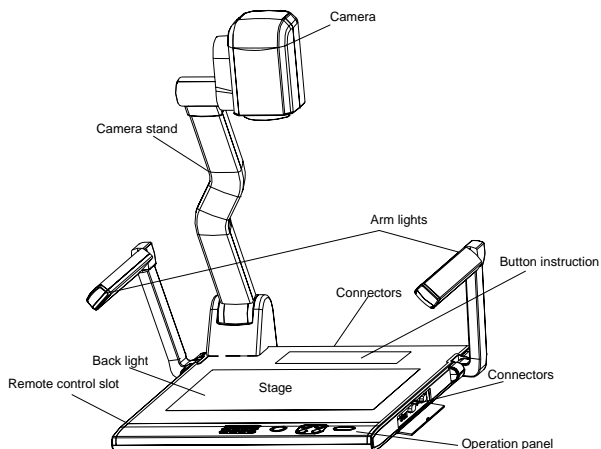

CONTROL PANEL

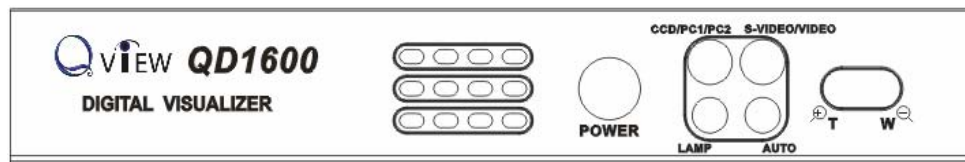

Rot (Rotate the image)

Frz (Freeze the image)

Neg (Display film negatives)

Text (Switch between image/text mode)

Save (Save captured images, can save up to 16 images)

Far/Near (Focus far or near)

Mem (Multiple Screen Display, the stored images will be displayed in a 2 x 2 matrix)

Ppw (Control the projector On/Standby)

Pin (Projector input signal selection)

↑/↓ (Move the image up/down)

POWER (Control the visualizer On/Off)

CCD/PC1/PC2 (CCD/RGB input signal selection)

VIDEO (S-VIDEO/ VIDEO input signal selection)

LAMP (Control the arm lights and back light)

AUTO (To auto adjust brightness, auto white balance and auto focus)

⊕/⊖ (Increase and decrease magnification)

Numerical Key (Saved image selection)

BUTTON INSTRUCTION

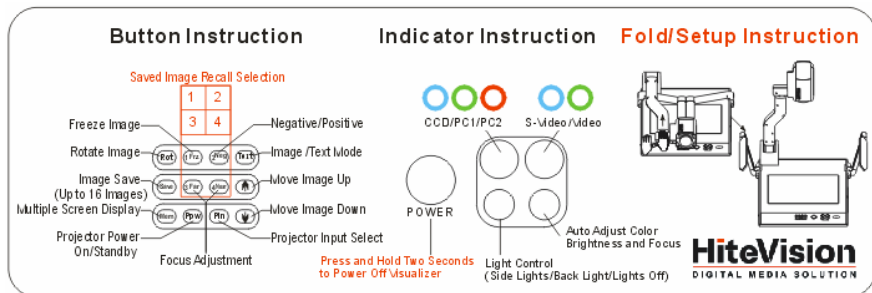

REMOTE CONTROL

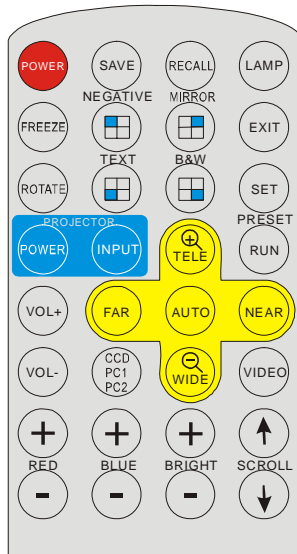

POWER (Control the visualizer On/Off)

SAVE (Save captured images, can save up to 16 images)

RECALL (Multiple Screen Display, the stored images will be displayed in a 2 x 2 matrix)

LAMP (Control the arm lights and back light)

FREEZE (Freeze the image)

NEGATIVE (Display film negatives)

MIRROR (V-Reverse the image)

ROTATE (Rotate the image)

EXIT (Exit selected function)

TEXT (Switch between image/text mode)

B&W (Switch between Color mode and Black & White mode)

SET (Preset 4 steps of Zoom/Focus position)

RUN (Run preset function)

PROJECTOR POWER (Control the projector On/Standby)

PROJECTOR INPUT (Projector input signal selection)

⊕TELE/WIDE⊖ (Increase and decrease magnification)

FAR/NEAR (Focus near or far)

AUTO (To auto adjust brightness, auto white balance and auto focus)

VOL+/- (Increase or decrease the volume)

CCD/PC1/PC2 (CCD/RGB input signal selection)

VIDEO (S-VIDEO/ VIDEO input signal selection)

RED+/- (Increase or decrease the red hue)

BLUE+/- (Increase or decrease the blue hue)

BRIGHT+/- (Increase or decrease the brightness)

SCROLL ↑/↓ (Move the image up/down)

CONNECTIONS

Rear Panel



Side Panel

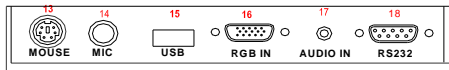

#1 AUDIO OUT

#2 VIDEO OUT

#3 S-VIDEO OUT

#4 VIDEO AUDIO IN

#5 VIDEO IN

#6 S-VIDEO AUDIO IN

#7 S-VIDEO IN

#8 PC AUDIO IN

#9 PROJECTOR Connector

#10 COMPUTER OUT

#11 COMPUTER IN

#12 POWER OUT/IN

#13 MOUSE

#14 MIC IN

#15 USB Connector

#16 RGB IN

#17 RGB AUDIO IN

#18 COMPUTER RS-232 Connector

BASIC PREPARATIONS

1. Use one hand holds the base of the visualizer, use the other hand carefully lift up the camera stand of the unit.

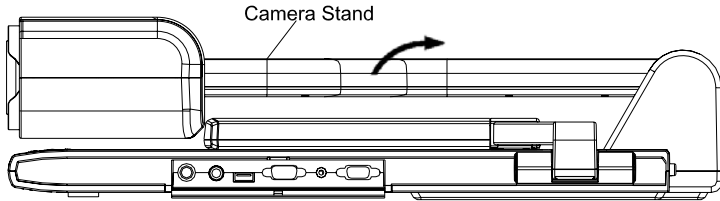

2. Open the arm lights and rotate the camera head until they are in proper positions.

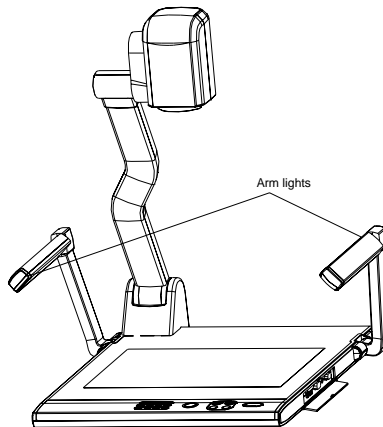

3. Making connections:

Before making any connection, **turn off all the power**, including power of the visualizer and the equipment to be connected.

Step 1: Connect power source.

First connect the power cord to the **12V IN** connector.

Step 2: Connect to the projector.

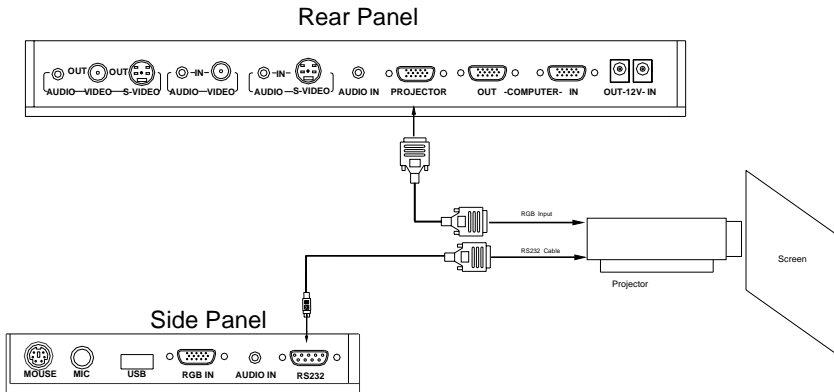

Connect visualizer's PROJECTOR port to the RGB IN port of the projector port with the RGB cable provided together the visualizer.

If you need control a projector with the visualizer, please use the projector RS232 cable (9-pin to 9-pin) to make the connection between the projector and the visualizer. Some projector models may require a converter cable in addition to this standard RS232 cable to connect to the projector control port, for the pin locations and shape of some projectors' control port connector may be different from the connector of a standard RS232 cable. After the visualizer is connected to the projector, you can control projector's power on, standby and input selection with the visualizer. (For projectors other than Hitachi, the Code Writing program that comes with the visualizer is required for this function.)

Step 3: Connect to a desktop computer.

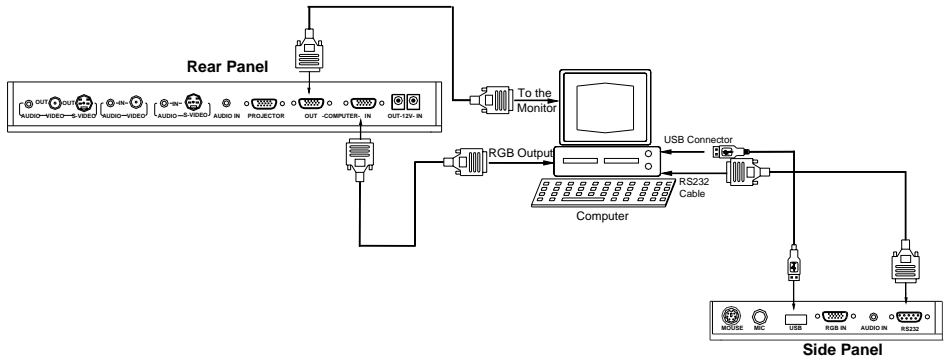

Note: You can connect a laptop computer to the RGB IN port of side panel with a RGB cable.

Step 4: Connect to the first video equipment with S-Video input.

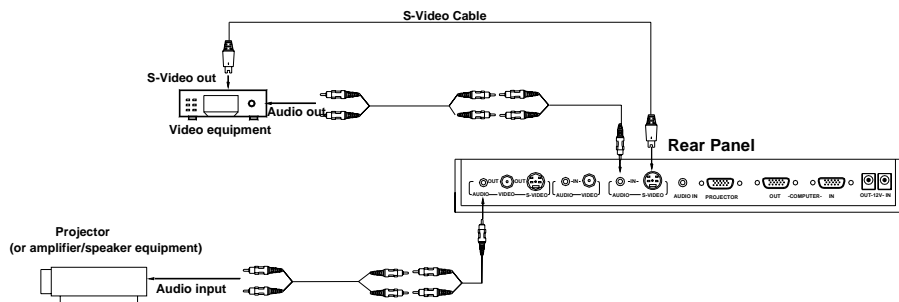

Output of the S-Video signal from the visualizer to the projector is already done in the step 2, where the RGB cable comes out from the visualizer and goes to the projector. After the connections as steps 2, 3, 4 are made, input

signals from the computer, visualizer CCD and S-Video are going to the RGB1 input on the projector and will be displayed on the projector screen as RGB1. These signals can be seen in turn when pressing “CCD/PC1/PC2” and “S-VIDEO/VIDEO” on the control panel of the visualizer.

Step 5: Connect to the second video equipment with video input.

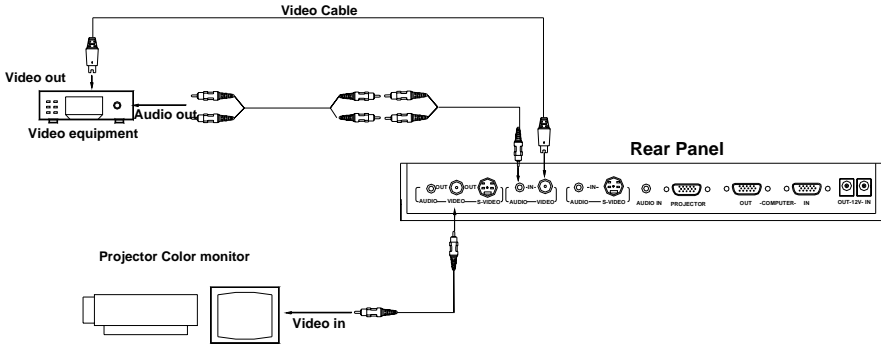

Step 6: Connections for external control from the computer.

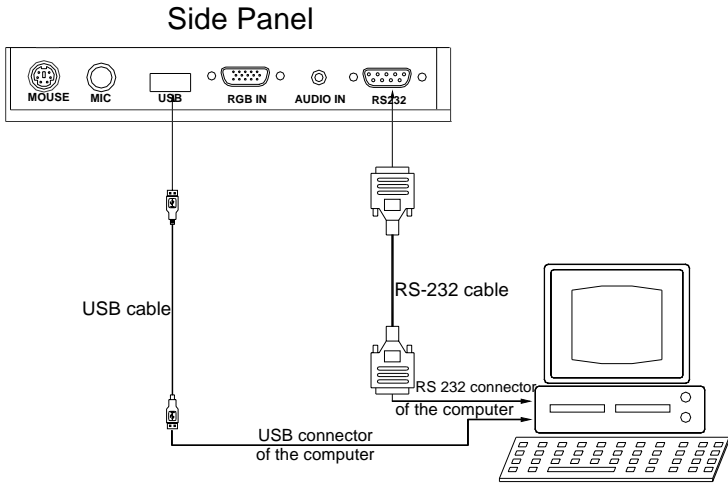

Use the computer RS232 cable (9-pin to 9-pin) to make the

connections shown below to control the visualizer from an external computer.

USB connection enables capturing still images / video streams from the visualizer to the computer. Special software is required for this operation.

4. Turn on the power by pressing the “POWER” button.

OUTPUT MODE AND VERTICAL FREQUENCY (60Hz)

The RGB output can output a signal in the SVGA /XGA format.

In order to achieve the best picture quality you must set the outputs of the Visualizer to match the native resolution of your display unit.

PAL/NTSC VIDEO OUTPUTS

The S-Video and composite video outputs are set to NTSC (PAL) during manufacturing.

INSTALLING VISUALIZER SOFTWARE

This function is to snap and display images with the USB interface, which includes displaying static and dynamic pictures, snapping dynamic images and playback the dynamic images with the media player in Windows XP.

- A. Connect the computer and visualizer with the USB cable. Insert the software CD that comes with your purchased visualizer into the CD-ROM drive. Turn on the visualizer. The setup will run automatically on your system, and then the Software Setup window will appear as below.



B. Click , you will see the following setup window:

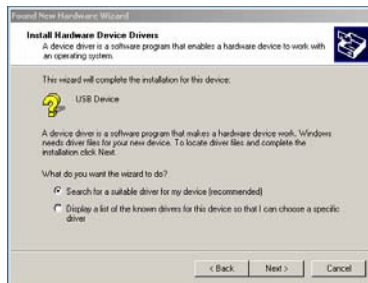

C. Click  and select CD-ROM drives, you will see the following setup window:



D. Click , then copy files



E. Click  to finish the setup.



F. Shut down your computer when prompted, so the changes will take effect.

*** Please pay attention to the following:**

1. Computer hardware requirement: CPU: 2.4GHz, RAM: 256M or above, Graphic card 64M, USB 2.0 port, Hard disk 40G or more, Monitor display resolution higher than XGA (1024*768).
2. Operating system: Windows XP SP2 (Service Pack 2).
3. Must use the high-speed USB cable provided together with the visualizer.
4. When connect the visualizer to a desktop computer with the high-speed USB cable provided together with visualizer, we recommend using the USB port on the rear of the mainframe as the USB port on the front of the computer might have interference.

WORKING ON THE STAGE

1. Place your material on the working surface.
2. Select the enlargement required with the “**T**” and “**W**” keys.
3. Adjust the focus with the “Near” and “Far” keys or “AUTO” key.

WORKING OUTSIDE THE STAGE

For showing 3-dimensional objects with the visualizer, just place them on the working surface and adjust the “**T**” or “**W**” and “AUTO” keys. If the object is too big for the stage or you want to show it from the side, just place it behind or in front of the unit and tilt the camera by hand (please take off the close-up lens first).]

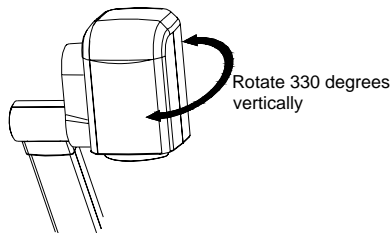

LIGHT

The arm lights are on when the power is on. Each time you press the “LAMP” buttons, the lighting changes as below.

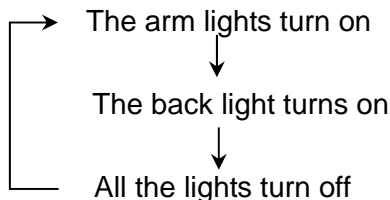

ADJUSTING IMAGE SIZE

In order to reduce or enlarge the image size displayed on the screen, press the “**T**” or “**W**” button.



WIDE



TELE

WORKING WITH NEGATIVES

The visualizer is automatically set to display normal materials on the screen when the power is on. To display negatives, turn on the backlight by pressing the “LAMP” key, and then press the “Neg” button to display the film negatives. Press the “Neg” button again to display normal materials in the color mode.



Positive

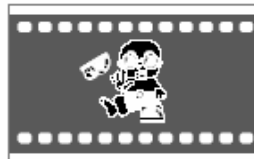

Negative

FOCUSING

When the Visualizer is turned on the focus automatically adjusts to the stage, it is not necessary to readjust the focus if you are only working with flat materials (text, photos, etc.). Only 3D objects require a focus adjustment.

Press the “AUTO” button to auto focus.

Press the “FAR” or “NEAR” button once to focus manually.

FREEZING IMAGE

Press the “Frz” button to freeze the image. When the output signal is RGB, in order to show a still image on the screen, press the “Frz” button. The frozen image can’t be adjusted (Zoom in/out, color adjustment, etc.).

BRIGHTNESS ADJUSTMENT

If the image effect is not satisfactory, you can adjust the brightness to get a better image effect. Use the “BRIGHT +” or “BRIGHT -” button to adjust the brightness. To increase the brightness, press the “BRIGHT +” button. To decrease it, press the “BRIGHT -” button. To go back to the initial brightness press the “AUTO” button.

WHITE BALANCE ADJUSTMENT

Each time the lighting condition changes, the user should adjust the white balance of the CCD.

Press the “AUTO” button to adjust the white balance automatically.

AUTO ADJUSTMENT

One of the Visualizer’s special functions is auto adjustment. Press the “AUTO” button to auto adjust the brightness, the white balance and the focus.

TEXT/IMAGE MODE

Press the “Text” button to switch between image/text modes. To display a text file, switch to the text mode to get a clearer text effect.

COLOR AND B&W MODE SWITCH

Press “B&W” once to enter the Black & White mode; press again to return to the Color mode. (On the remote control)

SWITCHABLE VIDEO INPUTS

Press the “VIDEO” button to switch among S-Video and Video signals.

SWITCHABLE RGB INPUTS

Use the “CCD/PC1/PC2” button to switch between CCD and different RGB signals. Each time the “CCD/PC1/PC2” button is pressed, it provides seamless transitions among different sources such as Camera (CCD)、COMPUTER(IN)、and RGB (IN).

Notes: RGB OUT always outputs RGB IN signals.

PROJECTOR ON/STANDBY

Press the “POWER” button to turn on the Visualizer’s power and press the “Ppw” button to turn the projector power on. To turn the projector standby after use, press the “Ppw” button more than 2 seconds, and then the projector enters to the standby mode. (On the remote control, press the “PROJECTOR POWER” button)

PROJECTOR INPUTS SELECTION

When the projector is connected to several input sources, use the “Pin” button to switch signal inputs of the projector. (On the remote control, press the “PROJECTOR INPUT” button)

IMAGE ROTATION

In order to rotate the image, press the “Rot” button once, the displayed image will be rotated 90/180/270 degrees clockwise. Press the “Rot” button again, the rotated image will be restored to the initial position.

IMAGE REVERSION

Press the “MIRROR” button once to mirror the image and the vertically mirrored image will be displayed. Press the “MIRROR” button again to exit.

INFRARED REMOTE CONTROL

The Visualizer’s remote control can control the camera from different angles. Please note that an infrared remote control can only be used up to









a certain distance to the unit. Objects situated between the visualizer and the infrared remote control and a weak battery may interfere with the reception.

On the left side of the visualizer stage, there is a built-in remote control storage compartment where you can store the remote control when you not use it.

PRESET FUNCTION

Use the “SET” button to preset 4 steps of the Zoom/Focus position, when the button is pressed, it moves step by step. Press “RUN” button to the run preset. (On the remote control)

2 X 2 MULTIPLE SCREEN DISPLAY

Press “Mem”, the stored images can be displayed in a 2 x 2 matrix. Press “Mem” once, the stored first four images can be displayed in a 2 x 2 matrix. Press the  button to display the upper left image; press the  button to display the upper right image; press the  button to display the lower left image; press the  button to display the lower right image. Press “Mem” twice, the stored second four images will be displayed in a 2 x 2 matrix, the operation of , , ,  is the same. Under this operation, the “Frz”, “Neg”, “Far” and “Near” button do not function. Press “Mem” the fifth time to exit the 2 x 2 image display mode.

On the remote control, the “RECALL”, , ,  and  button can do the operation.

USB PORT

The USB port can be used to store still images from the visualizer in a computer. No additional computer hardware is required. In this way, the visualizer can be used as a 3-D scanner for your computer.

Connect the Visualizer to your computer with the supplied USB cable. The Visualizer Software is available on the supplied CD-ROM.

USB IMAGE CAPTURE

You can capture and control images on the visualizer from a computer connected with a USB connector.

- A. Connect the computer and the visualizer with the USB cable.
- B. Double click X:\ USB Capture\setup.
- C. click [start] -> [All Programs] -> proscancamera -> proscancamera, you will see the following computer control window:



The control keys' operation is the same to the operating instruction of the "Controlling the Visualizer From a Computer" section.

- D. Menu operation instructions.



Display the image in full screen.



Get a present picture frame from CCD.



Save the captured image to computer.



Print the captured image.

CONTROLLING THE VISUALIZER FROM THE COMPUTER

You can control the visualizer from a computer connected with a RS232 connector.

- A. Connect the computer and the visualizer with the RS232 cable.
- B. Double click X:\ 232 Control\Control Panel (you can open this file from the CD and double click it, or copy this file to any directory on your computer's hard drive and double click to launch it).

CONTROLLING PROJECTOR BY VISUALIZER

The code writing software is used to inputting projector's control code, then can control various projector with the visualizer.

1. Connect the visualizer to the projector with the RGB、VIDEO、S-VIDEO cables.
2. Connect the RS232 cable to the computer's connector. The visualizer's RS232 port is located on its right side.
3. After completion of the connection, turn on the visualizer, click [start] -> [All Programs] -> Visualizer ->  Visualizer Code-Writing and the following dialog box appears as below:

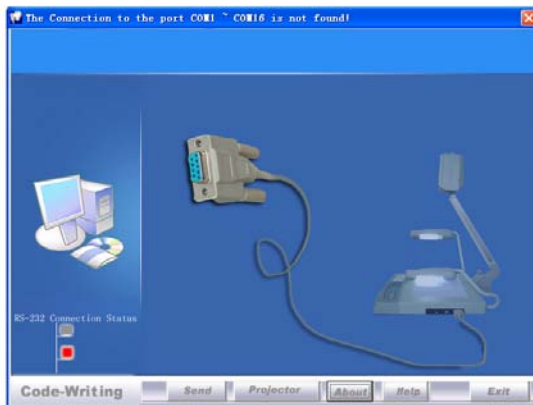

When the indicator of “Current RS-232 Connection Status” is green, that means the connection between the visualizer and the computer's RS232 connector is good. If the indicator is red, please check if the RS232 cable is connected correctly. When all the cables are connected correctly, please

click “Projector” to select your projector model under the drop-down list, then click “Send”. If you can not find your particular projector model in the “Projector”, please do the following:

- 1). Select “Baud rate” and “parity” and input the projector control code. (The baud rate, parity and control code is supplied by projector’s manufacturer, please refer to the projector’ manual)

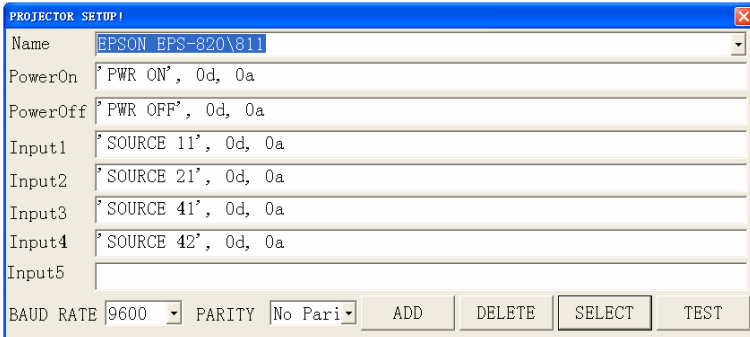

The input format of projector’s control code is as follows:

- a. If the data is in the numerical value format, please input data directly, block them off with comma, do not distinguish lowercase and uppercase.

For example: the “POWER ON” code in Hitachi projector manual is :

BE	EF	03	06	00	BA	D2	01	00	00	60	01	00
----	----	----	----	----	----	----	----	----	----	----	----	----

In the POWRE ON box,Input : be, ef, 03, 06, 00, ba, d2, 01, 00, 00, 60, 01, 00. Then use the same input rule to input other code.

- b. If the data is in the character string format, input ‘character string’.

For example: the “POWER ON” code in the SHARP C40/50 projector manual is :

P	O	W	E	-	-	-	1	↵
---	---	---	---	---	---	---	---	---

(“-“ is space, ↵ is enter.)

In the POWER ON box, input 'POWER 1', 0d, 0a

(Remarks: There are 3 spaces after POWER, 0d, 0a is enter.)

Input other codes in the same way.

c. If the data is in the numerical value and character format, then synthesize the above-mentioned formats.

3). Once done, click “Add” to add your projector model, then Click “Send”. Afterward, click “Ok”. Now, you can use the visualizer to control your projector.

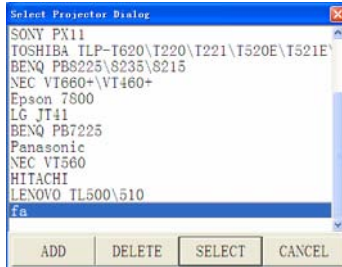

4. Connect the visualizer’s projector control port to the RS232 port with a RS232 cable (Please disconnect the computer from the RS232 port first) . Then use buttons on the operation panel to control the projector.

visualizer provides a 9-pin to 9-pin RS232 cable. If this cable does not match to your projector’s RS232 port, an additional RS232 cable is needed. This additional RS232 cable can be made based on the pin location of the projector’s RS232 control port. The pin locations of the visualizer are: the pin 2 is RXD (Received Data); the pin 3 is TXD (Transmitted Data); the pin 5 is GND (Ground). Other pins are not defined. The pin location information of the projector is provided by the projector’s manufacturer. The projector’s RS232 control port normally has RXD pin, TXD pin and GND pin, the name may be different. The parallelism of each data pin is shown as follows:

Visualizer’s RXD pin-----Projector’s TXD pin
Visualizer’s TXD pin-----Projector’s RXD pin
Visualizer’s GND pin-----Projector’s GND pin

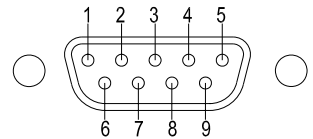

5. If you can not use buttons on the operation panel to control the projector, please use Code-Writing software’s projector control code testing function check if the control code is correct.

Click “Projector” button, the following dialog box appears as below:

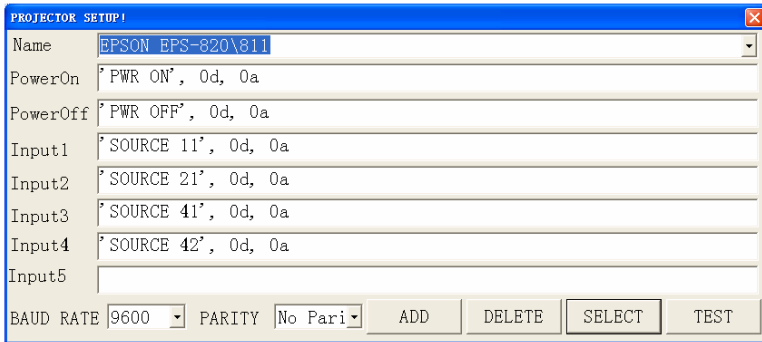

Connect the Visualizer to a computer with a RS232 cable (Please disconnect the projector from the RS232 port first) and select the Baud Rate and Parity based on the projector’s Baud rate, then click the “TEST” button to pop up the Projector Code Test dialog box, input the Baud Rate and Parity based on the projector’s Baud rate, then click “Open”.

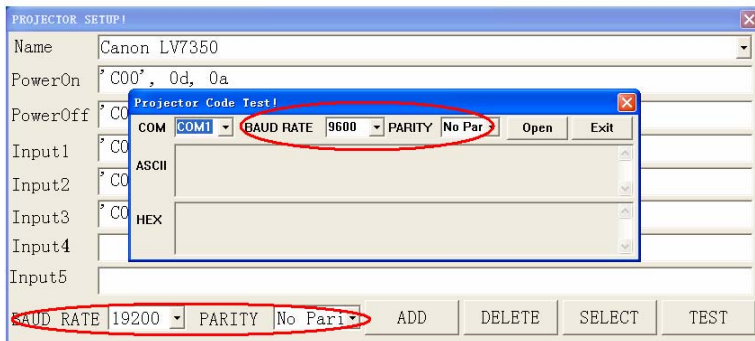

Click the projector control buttons on the Visualizer’s operating panel to check if the control code that the program received is the same as the sending code. If the receiving code is same to the sending code, the input codes are correct. If the Visualizer can not control the projector, please do the following.

1. Check to see if the source control codes of projector are correct.
2. Check to make sure the connection between the Visualizer and the projector is correct.

CONTROLLING CAMERA BY MOUSE

Connect the mouse to the visualizer. You can control the camera by mouse. The control menus' operation is the same to the operating instruction of the "Controlling the Visualizer From a Computer" section.

Side Panel

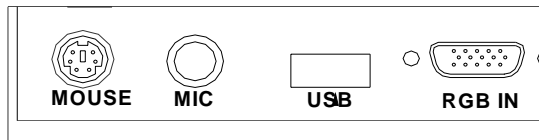

FOLDING THE UNIT

1. **Fold** the right arm light down first onto the base, then the left arm down. **Rotate** the camera head clockwise until the camera head is parallel to the camera stand.

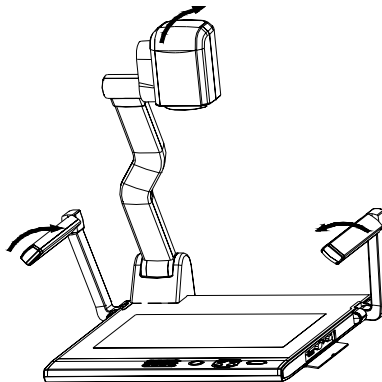

2. Carefully **Fold** the camera stand down to the front panel.

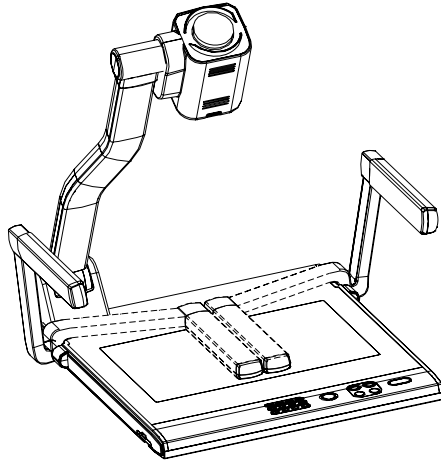

Cautions:

- a. Don't lay the unit down flat.
- b. Don't try to stand it on its rear or sides.
- c. Don't try to pick up this unit by pulling the camera stand.

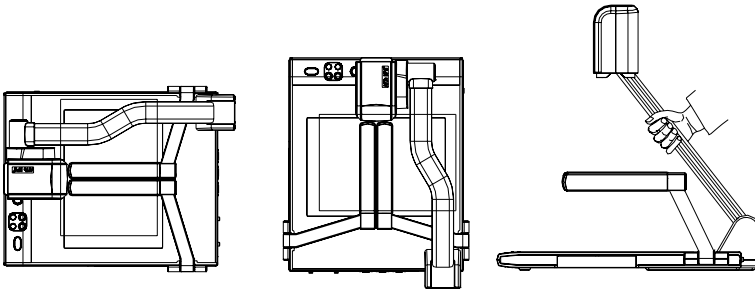

NOT THIS WAY

SPECIFICATIONS

Color system	NTSC or PAL system
Pickup device	1/3" CCD
Resolution	XGA (1024 x 768)
Total Pixels	850,000
Lens	16 x optical zoom, 10 x electrical zoom
Zoom	Powered
Camera Rotation	Vertically 330°
Focus/Iris	Auto/manual selectable
White balance	Auto
Camera Mouse	Yes
Negative/positive conversion	Yes
Black/white and color selection	Yes
Image Freeze	Yes
Emboss conversion	Yes
Edge conversion	Yes
Image Mirror	Yes
Image Rotate	0° 90° 180° 270°
Image Flip	Yes
Image PIP	Yes
Image Split	Yes
Image Save & Recall	16 frames save
Camera Mouse	Yes
Lights	Arm light: 1.5W LED lamps x 2
	Back light: 4W LED lamps
Input connectors	C Video IN (RCA) (1)
	S Video IN (4-pin DIN) (1)
	Audio IN (Mini Jack) (2)
	MIC IN (phone jack)(1)
	PC Audio (2)
	RGB DB15FLC (2)

Output connectors	RGB DB15FLC (2)
	C Video OUT (RCA) (1)
	S Video OUT (4-pin DIN) (1)
	Audio OUT (Mini Jack) (1)
Operating system	Windows XP SP2 (Service pack 2)
Hardware Requirement	CPU higher than P2.4GHz Memory higher than 256 MB
Frame Rate	25 frames/sec
RS-232 connector	D-Sub, 9-pin, male
USB port	USB 2.0
Power requirements	12V/4A external AC adapter
Dimension (W x D x H)	Folded: 20.1" x 16.1" x 4.7"
	Setup: 20.1" x 20.9" x 22.4"
Weight	N.W: 5.5Kg (12.1lbs)
	G.W: 9.5Kg (20.9 lbs)
Accessories	AC power cord RGB cable Audio/Video cable S-Video cable Computer RS232 cable (9-pin to 9-pin) USB cable Audio convert cable AC adapter User's manual Software CD Infrared remote control Warranty card Mouse

* Design and specifications are subject to change without prior notice.

TECHNICAL SUPPORT

How to Reach QOMO:

By Phone

Call us at 1-866-990QOMO. Our expert personnel provide technical assistance from 9:00AM through 5:00PM Eastern Standard Time, Monday through Friday. Please gather the following information before calling:

- Product model name(s) and numbers
- Product serial number(s)
- Detailed and specific questions

Online

Technical support is also available online at QOMO's web site at www.qomo.com. You can enter your questions and concerns through our online form. Or you can email us at info@qomo.com.

Copyrights © 2004 QOMO Hitevision, LLC. All Rights Reserved.